

TECHMOUNT P/N 3-10105 kit

The StemMount is designed to snugly fit into the steering stem hole, in the top triple clamp assembly. If your bike has a rubber plug in this hole, it must be removed.

The mount system can be easily converted to fit many different bikes by removing the o-ring post and installing any of the other sizes (see chart below for correct size) that fits your bike.

1. Dampen the rubber o-rings with a small amount of water.

2. Grab the Stem Mount shaft and firmly press and rotate the mount into the top of your steering stem hole until the base of the Stem Mount touches the stem nut.

3. Adjust the angle of the top plate and shaft to the desired level and tighten with the supplied 3/16" wrench.

4. Attach the supplied Velcro to the device and to the top plate.

The Stem Mount is removed by pulling upward firmly while rotating slowly.

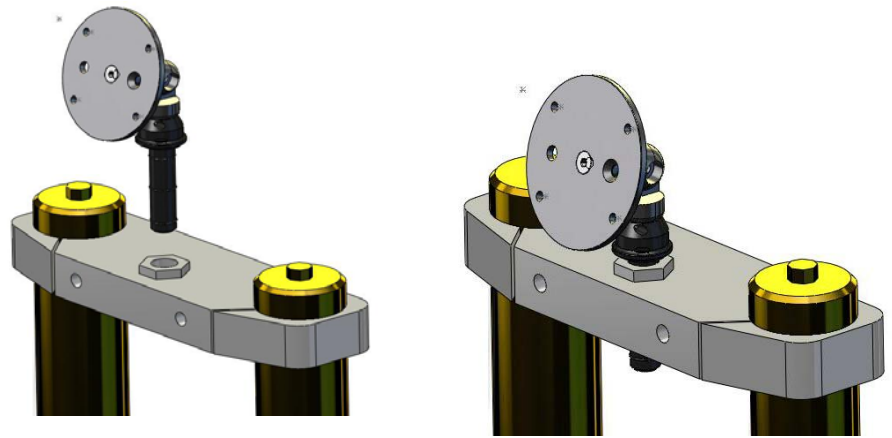

13 mm O-ring Post

Honda

CBR900RR (1993-2000)
 CBR929RR (2000-2001)
 CBR954RR (2002-2003)
 RVT1000R RC51 (2000-2001)

Kawasaki

Ninja ZX-6R (1999-2002)
 Ninja ZX-9R (1994-2003)
 ZZR1200 (2006)

Suzuki

DL1000 V-Strom (2002-2004)
 GSX-R1000 (2005-2006)
 GSX-R1100 (1991-2002)
 GSX-R600 (1997-2006)
 GSX-R600 (1992-1993)
 GSX-R750 (1991-2005)
 GSX1300R Hayabusa (All)
 TL1000R (1998-2003)

Yamaha

YZF-R1 (2004-2008)
 YZF-R1 (1998-2001)
 YZF-R1 LE (2006)
 YZF-R6 (1999-2008)

16 mm O-ring Post

Kawasaki

Ninja ZX-10R (2004-2006)
 Ninja ZX-12R (2003-2007)
 Ninja ZX-14R (2006-2008)
 Ninja ZX-6R (2003-2008)

Suzuki

GSX-R600 (2006 maybe 13mm)
 GSX-R750 (2006 maybe 13mm)
 GSX-R600 (2007-2008)
 GSX-R750 (2007-2008)

17 mm O-ring Post

Suzuki

GSX-R1000 (2003-2004)
Yamaha
 YZF-R1 (2002-2003)

18 mm O-ring Post

Honda

CBR600RR (2003 - 2008)
 ST 1300 (2004-2008)

19 mm O-ring Post

Honda

CBR600F2 (1991-1994)
 CBR600F3 (1995-1998)
 CBR600F4 | F4i (1999-2006)
 CBR900RR (1993-2000)
 VFR750F (1991-1997)
 VTR1000F SuperHawk (1998-2005)

24 mm O-ring Post

Honda CBR1000RR(2008-later)